



TMEiC
We drive industry

TMdrive[®]-XL75

Product Application Guide

Medium Voltage 5-Level Drive



WWW.TMEIC.COM

JAPAN | NORTH AMERICA | SOUTH AMERICA | EUROPE | SOUTHEAST ASIA | INDIA | CHINA | MIDDLE EAST | AUSTRALIA

TMdrive-XL75 High-Power Drive

Designed for Large Compressors

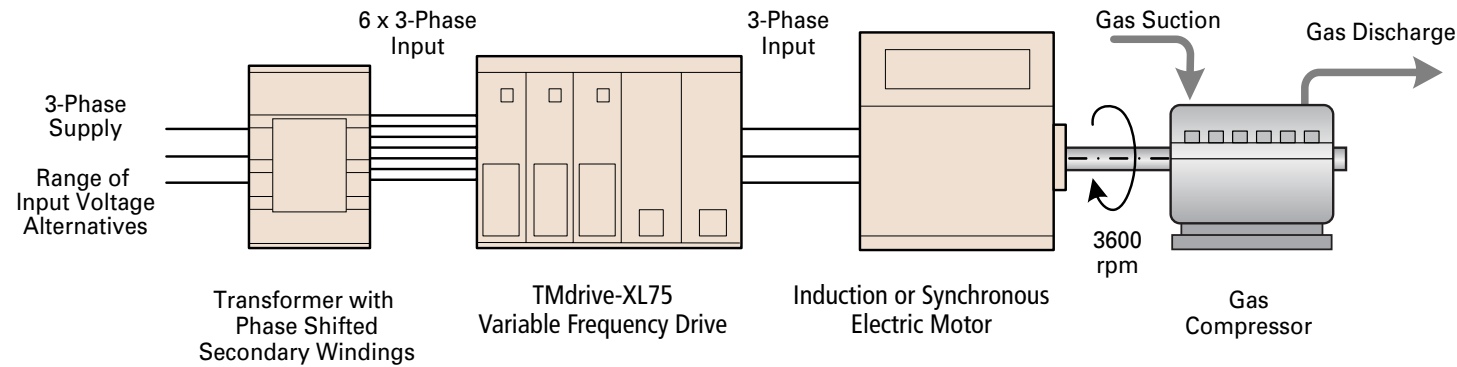







The TMdrive-XL75 variable frequency drive is designed to meet Oil & Gas industry needs for:

- High power
- High reliability
- Output frequency range for direct compressor drive
- Reduced energy consumption

Power Levels using parallel banks of TMdrive-XL75:

- One-Bank – 15 MVA, 23 MVA
- Two-Bank – 30 MVA, 46 MVA
- Three-Bank – 45 MVA, 69 MVA
- Four-Bank – 60 MVA, 92 MVA

Synchronous or induction motors can be driven.

Design Feature	Customer Benefit
 <ul style="list-style-type: none"> • Conservative design using MV 4500V 1500A and 2100A IEGTs 	<ul style="list-style-type: none"> • Highly reliable operation, expected 20 year drive MTBF
 <ul style="list-style-type: none"> • High energy efficiency of approximately 98.6% 	<ul style="list-style-type: none"> • Considerable energy savings
 <ul style="list-style-type: none"> • Diode rectifier ensures power factor greater than 95% in the speed control range 	<ul style="list-style-type: none"> • Capacitors not required for power factor
 <ul style="list-style-type: none"> • 36-pulse converter rectifier by using phase shifted transformer 	<ul style="list-style-type: none"> • No harmonic filter required to provide lower harmonic distortion levels than IEEE-519-1992 guidelines
 <ul style="list-style-type: none"> • Five level drive output waveform to the motor 	<ul style="list-style-type: none"> • Smooth output voltage, motor friendly wave form
 <ul style="list-style-type: none"> • Externally mounted input isolation transformer 	<ul style="list-style-type: none"> • Less power loss in drive room • Less total space required • Simplifies design and installation
 <ul style="list-style-type: none"> • Up to 6.6 kV direct drive voltage output level 	<ul style="list-style-type: none"> • No output transformer required, saving cost, mounting space, and energy



Liquefied Natural Gas Plants

LNG plants have large refrigeration compressors driven by high power turbines or electric motors with speeds of over 3,000 rpm. The TMdrive-XL75 combined with TMEIC's two-pole synchronous motor is specially designed for this application.



Gas Pipelines

Large compressors on gas pipelines require high power and speed – usually provided by gas turbines. Replacing the turbine with an electric motor and TMdrive-XL75 drive provides higher reliability, uptime, and efficiency, and in addition, NO_x and noise are eliminated.



Chemical Plants and Refineries

Large compressors requiring over 20,000 hp are found in refineries and chemical plants. The TMdrive-XL75 drive and electric motor offer high-reliability, high-availability, lower pollution, and lower noise level for these applications.



Steel Plants

Steel plant blast furnaces use large air flows requiring high power levels, which can be supplied by the TMdrive-XL75 drive.

A Look Inside

Advanced Technology for High Power

- Conservative design using 4500 V, 1500 or 2100 A IEGTs
- Water-cooling technology for the power bridge reduces drive footprint, saving valuable space
- Modular design power bridge minimizes time for any maintenance activities



U-Phase

V-Phase

W-Phase

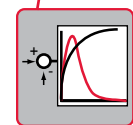

Main Control Panel

The primary control board provides:

- Speed and torque regulation
- Sequencing
- Diagnostic data gathering
- Optional LAN interface board

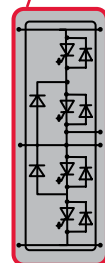

IEGT Cell Stack Assembly

The drive has a total of six IEGT cell stack half modules in the inverter. The modular draw-out assembly includes:

- Four IEGT power semiconductors
- Two neutral-point clamp diodes
- Water cooling piping with quick disconnect fittings
- IEGT gate driver circuit board



Water Cooling Tubes for Cell Stack Assemblies

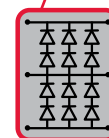

Diode Rectifier DC Source Modules for W-Phase



Capacitors for W-Phase



Pump Panel

TMdrive-XL75 Architecture

TMdrive-XL75 high-power level architecture consists of:

- Two diode rectifier modules per phase
- Two inverter half-modules per phase
- Phase shifted transformer externally mounted

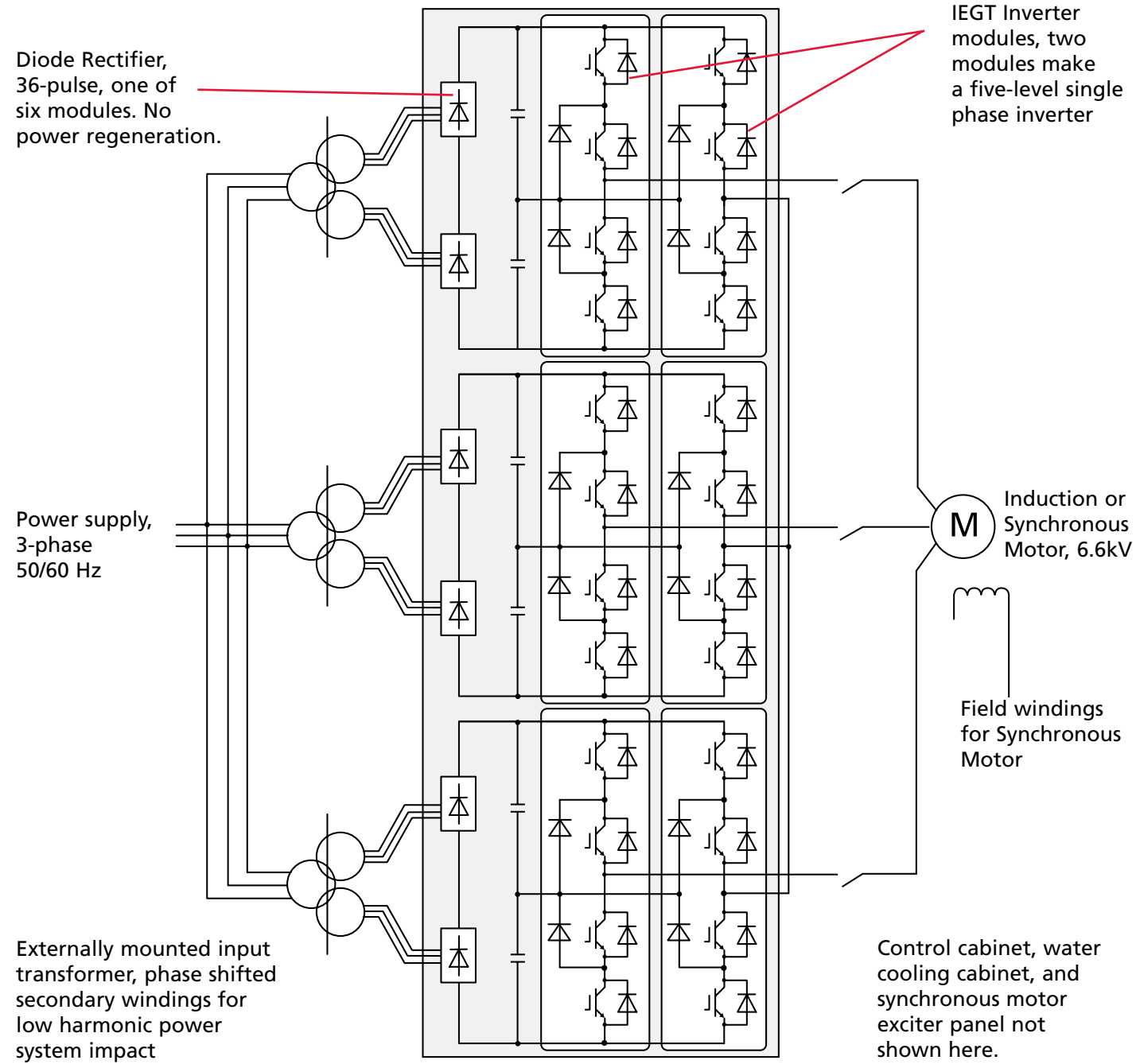

IEGT Inverter Module

This inverter half-module has four IEGTs rated for 1500 A or 2100 A, 4500 volts. Two modules make one inverter phase assembly.

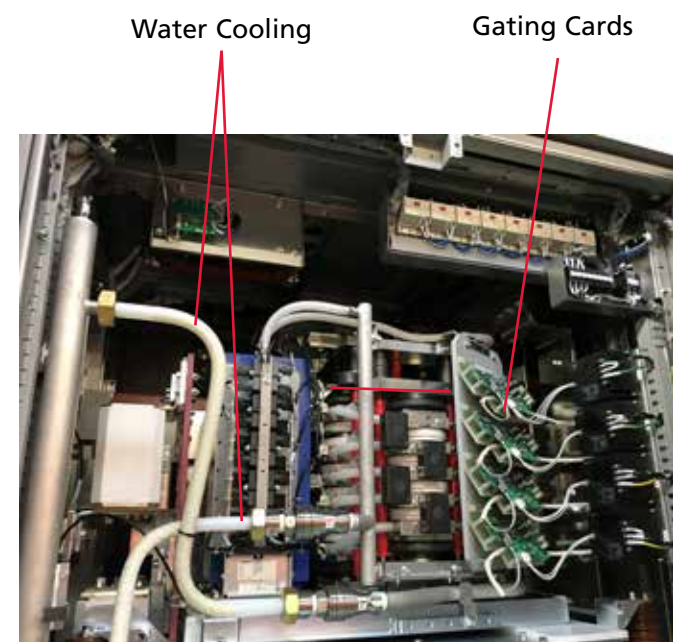
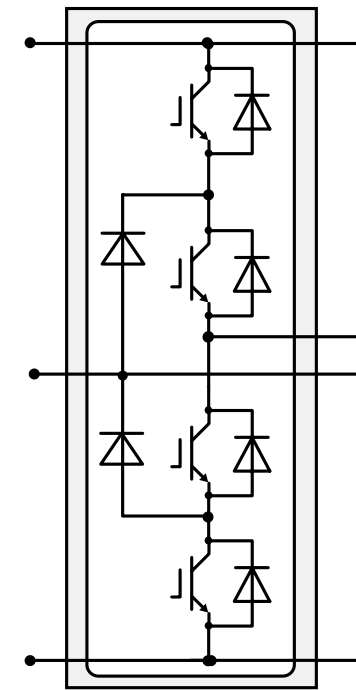

Inverter Half-Module



Diode Converter



TMdrive-XL75 Cabinet Line-Up

Top View

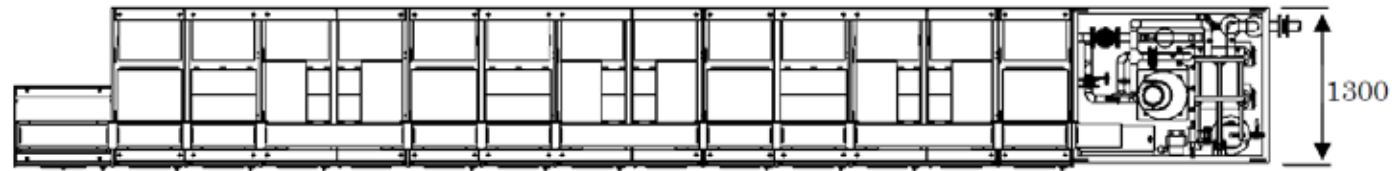

Front View

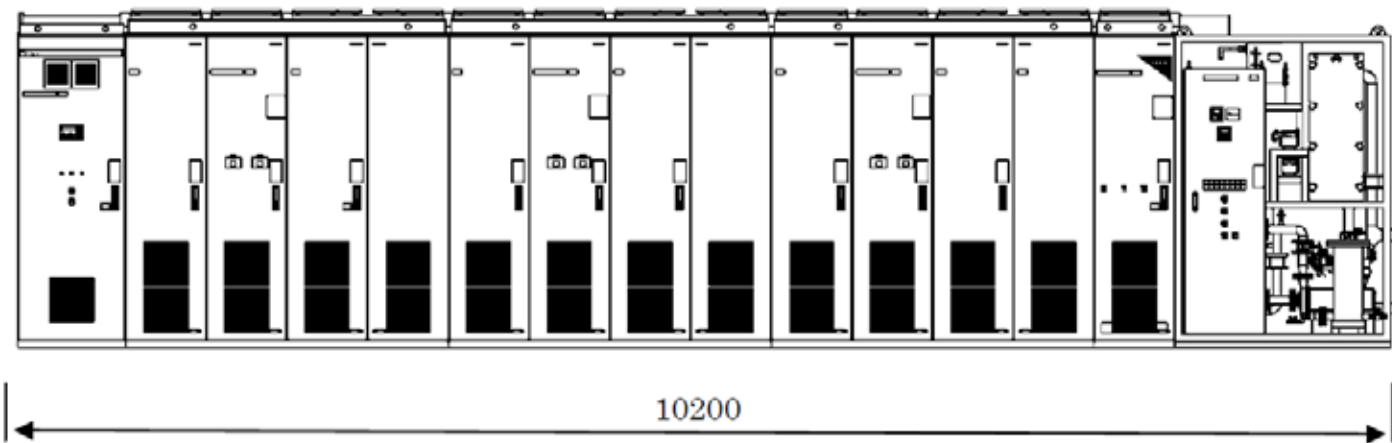

Drive Specifications

	Voltage kV	Power MVA	Motor Current A	Height mm (in)	Width mm (in)	Depth mm (in)	Weight kg (lbs)
Single Bank Drive	6.6	15	1325	2550 (100)	10200 (402)	1300 (51)	(30,423)
	6.6	23	2015				(32,628)

Dimensions shown are for a 23 MVA (23,000 kVA) single bank drive.
Power outputs up to 80 MVA will use multiple banks similar to above.
Weight is for line-up with no water, and does not include exciter panel.

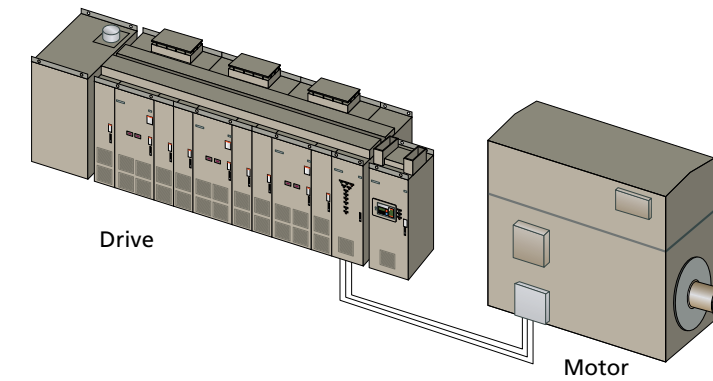

One-Bank XL75 Variable Frequency Drive

- Power level 23 MW
- One cooling water panel with included interface panel
- Synchronous motor 6.6kV
- Drive input transformer not shown

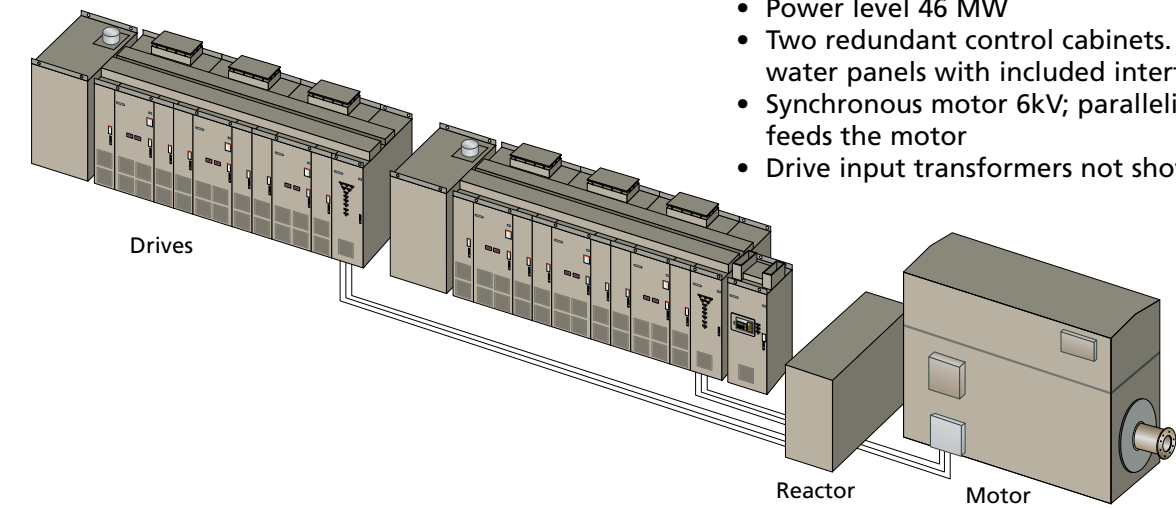

Two-Bank XL75 Variable Frequency Drive

- Power level 46 MW
- Two redundant control cabinets. Two cooling water panels with included interface panel
- Synchronous motor 6kV; paralleling reactor feeds the motor
- Drive input transformers not shown

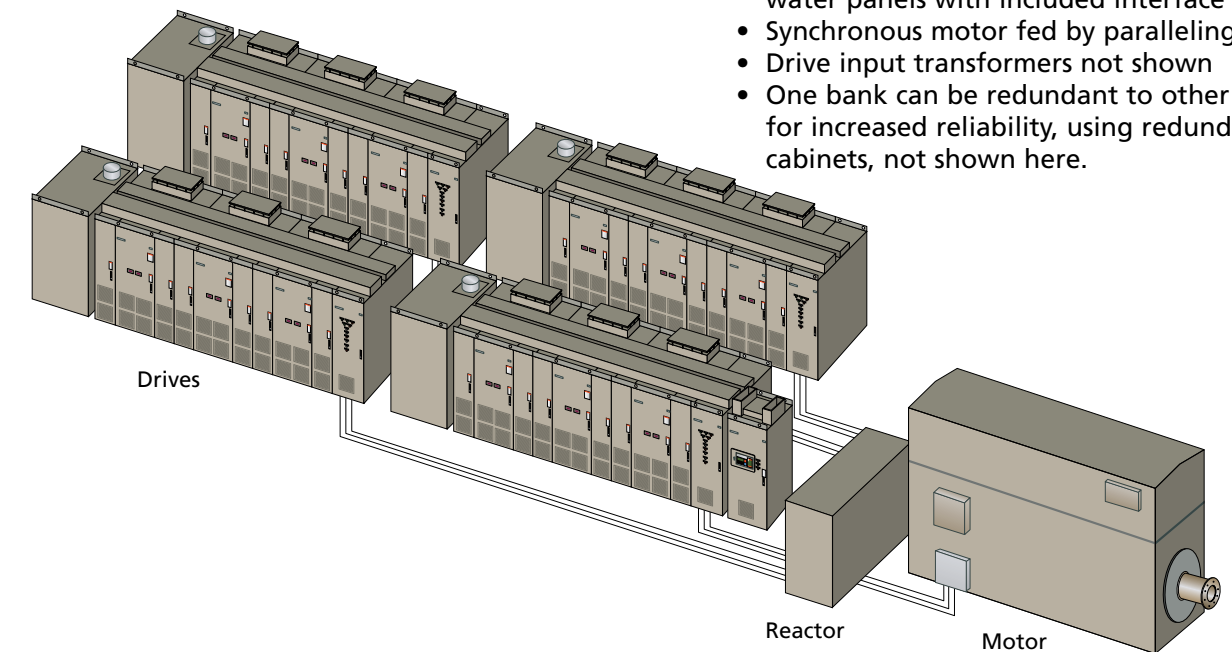

Four-Bank XL75 Variable Frequency Drive

- Power level 92 MW
- Two redundant control cabinets. Four cooling water panels with included interface panel
- Synchronous motor fed by paralleling reactor
- Drive input transformers not shown
- One bank can be redundant to other three banks for increased reliability, using redundant control cabinets, not shown here.

Features of the TMdrive-XL75

A Clean Wave Inverter

Using the multiple winding input transformer, the TMdrive-XL75 has 36-pulse rectification, which reduces the harmonic voltage distortion on the power source and protects the other equipment in the plant. The harmonic current content measured in an actual load test is compared with IEEE-519 in the chart opposite, showing it more than meets the standard.

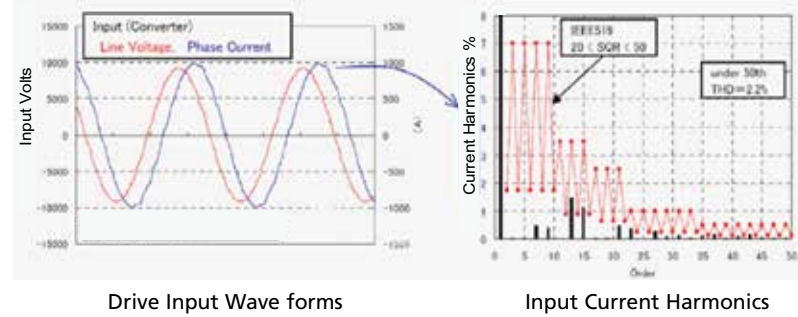

A Clean Output Wave

As a result of the five-level PWM control, the output current waveform is close to a sine wave, and the heat loss in the windings caused by harmonics is negligible. In addition, harmonic currents in the motor are minimized so there is very little torque ripple on the output shaft.

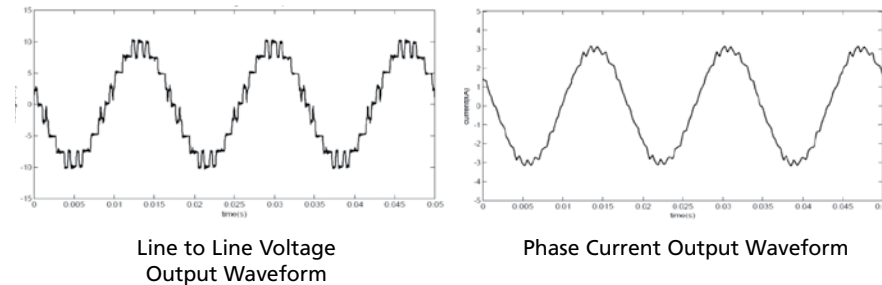

A Higher Efficiency than Conventional Drives

Actual factory load tests show the drive efficiency is approximately 98% (design value). This high efficiency is a result of:

- A smaller number of switching semiconductors by using 4.5kV IEGTs
- Lower switching frequencies using multilevel PWM control to reduce the switching loss of each IEGT
- Direct connection of 6.6kV motor without an output transformer

A High Input Power Factor

As a result of the diode bridge rectifier, the input power factor is above 95% over the entire normal operating speed range, even when driving a multiple-pole induction motor of low power factor. With this high power factor, no power factor correction capacitor is required.

TMdrive-XL75 Drive and Motor Testing

Back-to-Back Tests

The TMdrive-XL75 has been thoroughly tested under full load conditions in TMEIC's test facility shown below, designed for all the XL series drives. For these tests, TMEIC designed a 25 MW synchronous two-pole motor for 3600 rpm operation and a 25 MW synchronous four-pole generator for 1800 rpm operation. Power from the generator is sent

to four regenerative TMdrive-70 drives which return power to the supply. Output transformers match the 11 kV main power grid.

Full load and speed was applied to the drive and motor. The drive's new five-level inverter topology and sophisticated Pulse Width Modulation control was fully tested. The actual TMdrive-XL85 test is shown in the photograph.

25 MW TMdrive-XL85 five-level GCT drive to power the motor

Regenerative TMdrive-70 three-level IEGT drive to recirculate power back to the supply



25 MW synchronous 2-pole variable speed motor, 3600 rpm

Gearbox, 2:1 ratio

Synchronous 4-pole generator

Drive Test Data

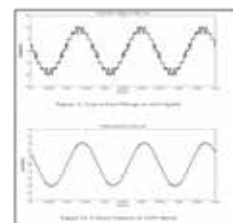

Drive output voltage and current at full speed

Drive Power MW



Motor Speed RPM

Center display: drive output volts to motor

The results of these tests demonstrated the suitability of electric drive systems for large compressor applications. Desirable system features were proven, such as a clean output waveform at full speed and generation of very little output torque ripple.



Environmental

Operating Air Temperature	0 to 40°C (32 to 104°F) at rated load 0 to 45°C (32 to 113°F) with derating
Storage Temperature	-25 to 70°C (-13 to 158°F)
Humidity	5 to 95% relative humidity Non-condensing
Altitude	Up to 1000 m Up to 3000 m with derating
Vibration	10-50 Hz, <0.5 G IEC 61800-4 5.1.22
Industrial Water Temperature	0°C - 40°C at inlet 0°C - 45°C at inlet with derate



Motor Control

- Speed regulator accuracy: $\pm 0.5\%$
- Maximum speed response: 5 rad/sec
- Torque range: 0-100% of rated motor torque

Without Speed Sensor (Induction Motor Only)

- Speed regulator accuracy: $\pm 0.5\%$ (using 1% slip motor at rated flux)
- Maximum speed regulator response: 5 rad/sec
- Maximum Torque current response: 50 rad/sec
- Torque range: 0-100% of rated motor torque

Pulse Width Modulation Control

- 0-25% speed, Asynchronous PWM
- 25-50% speed, Synchronous PWM
- 50-100% speed, Fixed Pulse Width

Variable Switching frequency up to 600 Hz



Power Input/Output

Input Voltage	6 x 1930 Vac $\pm 10\%$ 50/60 Hz $\pm 2\%$ Top or bottom cable entry	
Input Harmonics	IEEE 519 compliant without filters	
Power for Pre-charge, Gate Power, Cooling Fan, IRU, Relay	200 V (50 Hz) 3-phase without transformer 380/400/440/460/480/575/690 V using transformer	
Cooling Pumps	380 V-50 Hz 3-phase supply 400 V-50/60 Hz 480 V-60 Hz 200/220/460/575/690V-60 Hz (non-standard)	
Displacement Power Factor	.95	
Output Voltage	6600 Vac	
Output Current	Up to 2015 A rms	
Output Current Derating	Ambient Temp. 40°C	Derating 1.00
	45°C	0.94
Output Frequency	50-60 Hz, 50-200 Hz with derate above 100 Hz	
Output Chopping Frequency	600 Hz (max)	
Output Overload	110% for 60 sec.	

Restart after power failure of less than 2 seconds.

Standard Connection

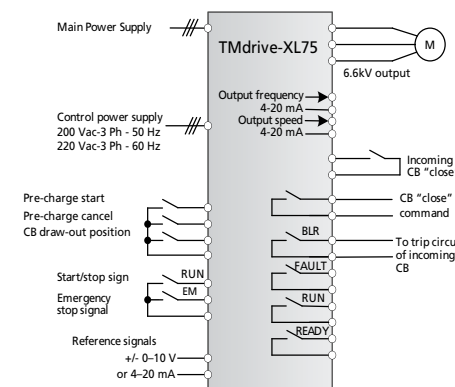

Control Area	Specifications
Analog Inputs	(2) $\pm 10V$ or 4-20 mA, configurable, differential, 12-bit
Analog Outputs	(4) $\pm 10V$ or 8-bit, configurable, 10 mA max, 12-bit
Digital Inputs	(2) 24-110V or 48-120V ac; (6) 24V dc, configurable
Digital Outputs	(6) 24V dc open collector 50 mA
Speed Feedback Resolver Input	1x resolver, up to 1024 pulses/rev 4x resolver, up to 4096 pulses/rev
LAN Interface Options	Profibus-DP, ISBus, DeviceNet™, TOSLINE® -S20, or Modbus RTU
Motor Temperature Sensor	Single high-resolution motor temperature feedback: 1 k Ohm platinum resistor or 100 Ohm platinum RTD (uses analog input with signal conditioner)

Mechanical Specifications

Enclosure

- IP42 except for fan openings (IEC 60529), NEMA 1 gasketed equivalent
- Color: Munsell 5Y7/1
- Front access

Cable Entrance

- Bottom or top entrance

Air Filters

- Air filters on front doors can be replaced with door closed

Sound

- Average is below 75 dBA one meter from cabinet

Control

Converter type

- AC-fed multi-pulse diode using phase shifted transformer
- No regeneration

Transformer

- Oil immersed type
- Air cooled
- Multi LV windings

Inverter

- Five-level inverter for motor friendly wave form
- Motor voltage: 6600 Vac
- Rated frequency: 50/60Hz
- 200Hz, maximum frequency
- Minimum input frequency 50Hz

Applicable Standards

- IEC61800-4, JIS, JEC, JEM, **CE** (option), CSA (option) UL (option)
- IEC 60146-1, 17 kV for 1 minute withstand

Control

- Nonvolatile memory for parameters and fault data
- Vector control with or without speed feedback
- Volts/Hz control for synchronous motor or induction motor

Protective Functions include:

- Inverter overcurrent, overvoltage
- Low or loss of system voltage
- Motor ground fault
- Motor overload
- Cooling fan abnormal
- Over-temperature
- CPU error
- Water cooling unit alarm
- Exciter fault
- DC voltage drop
- Motor reverse rotation
- Stall detection
- Ground detection

Cooling Water Conditioning Equipment

Operator Interfaces

Types of Water Cooling Systems

- Closed Loop - No Plant Water**
- Water-to-air Exchanger
 - Redundant pumps and fans on exchanger

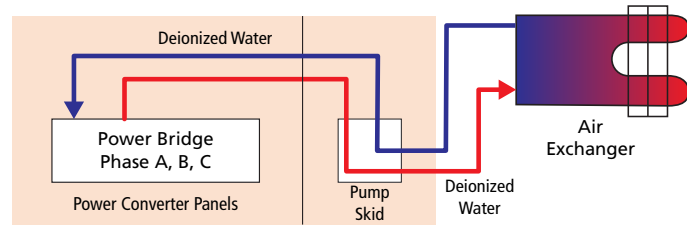

- Open Loop - Customer Cooling Water**
- Water-to-water Heat Exchanger
 - Specific plant water temp. needed
 - Redundant pumps

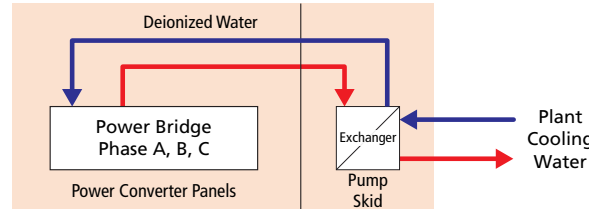

Water conditioning control panel continuously monitors the status of the water system. Separate fault indications help find and fix problems fast. Operator panel shown on page 15.

A typical water conditioning skid includes a water to water heat exchanger and surge tank.

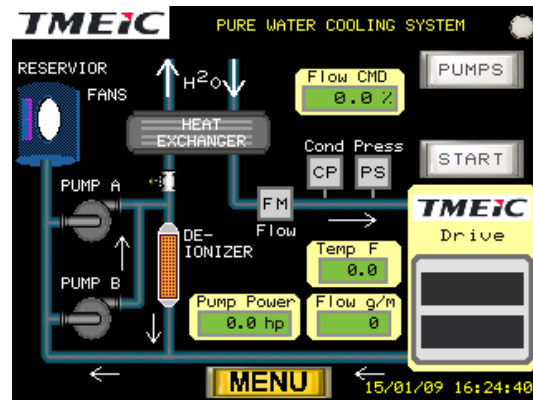
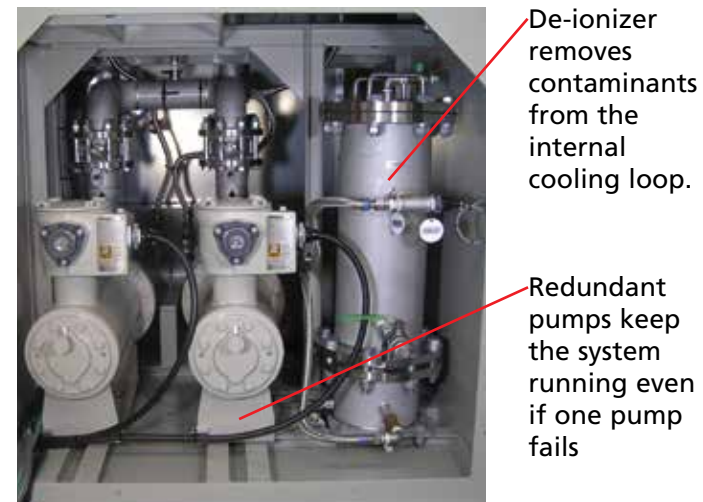

Cooling Equipment

Type	Heat Exchange Capacity kW	Width mm (in)	Depth mm (in)	Height mm (in)	Weight kg (lbs)	Power Supply kVA
23 MVA	220	1828 (72)	1219 (48)	2286 (90)	1587 (3500)	12
15 MVA	150	1828 (72)	1219 (48)	2286 (90)	1587 (3500)	12

Inlet Cooling Water Temperature Requirements & Power Derating

Cooling Water	Maximum Water Temperature °C (°F)
	One Bank
Cooling water supplied by plant (Industrial water) (460 L/Min)	40 (104)
Cooling, de-ionized water flowing through the power unit (Pure water)	45 (113)

Standard Display

Compact Control Panel (Single Bank or Two Banks)



- Fault Lamp
- AC Off Lamp
- Pre-charge Switch
- Local/Remote Switch
- AC On Lamp

Interface and Water Cooling Panel



- De-ionized Water Quality Monitor
- Indicator Lights and Labels

Keypad

High Function Display

- LCD backlight gives great visibility and long life
- Bar graphs, icons, menus, and digital values combine to provide concise status information, often eliminating the need for traditional analog meters



Easy-to-understand navigation buttons allow quick access to information without resorting to a PC-based tool

Switch to local mode and operate the equipment right from the keypad

RJ-45 Ethernet port is used for the local toolbox connection

Instrumentation Interface

- Two analog outputs are dedicated to motor current feedback
- Five analog outputs can be mapped to variables for external data logging and analysis

Interlock button disables the drive



TMEIC AC Drives Offer Complete Coverage

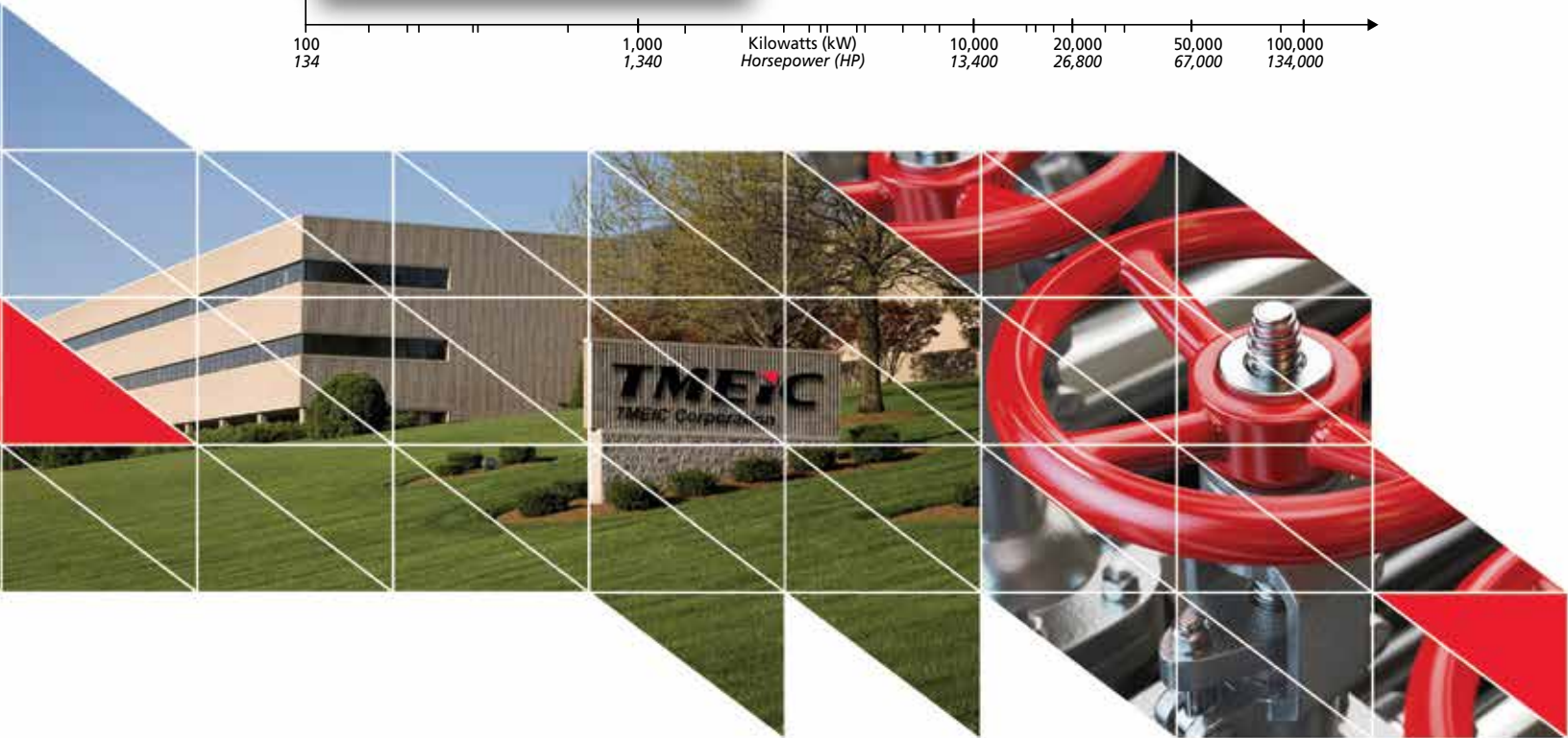
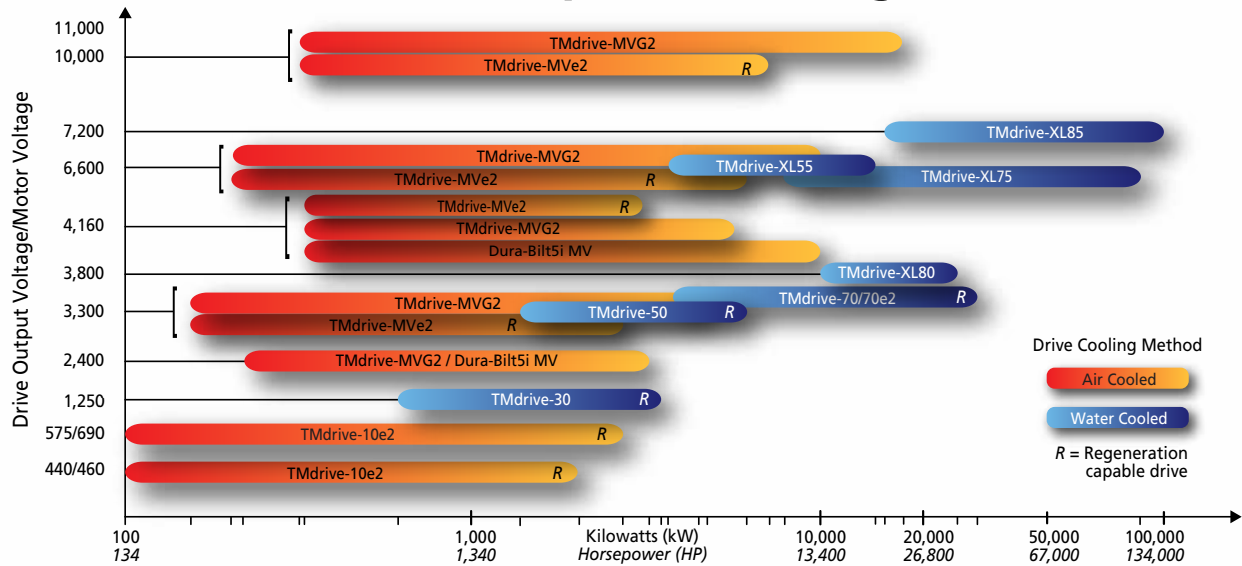

TMEIC Corporation | Roanoke, Virginia, USA | GI@TMEIC.COM | WWW.TMEIC.COM

All specifications in this document are subject to change without notice. This brochure is provided free of charge and without obligation to the reader or to TMEIC. TMEIC does not accept, nor imply, the acceptance of any liability with regard to the use of the information provided. TMEIC provides the information included herein as is and without warranty of any kind, express or implied, including, but not limited to, any implied statutory warranty of merchantability or fitness for particular purposes. The information is provided solely as a general reference to the potential benefits that may be attributable to the technology discussed. Individual results may vary. Independent analysis and testing of each application is required to determine the results and benefits to be achieved from the technology discussed.

TMdrive is a trademark of TMEIC Corporation.
© 2020 TMEIC Corporation. All Rights Reserved.

D-0010
Revised April 2020